

# MODEL 258

## 3-Phase Monitor

- Detects phase loss, low voltage, phase reversal
- 50Hz, 60Hz and 400Hz models
- Automatic or manual reset
- Five year unconditional warranty

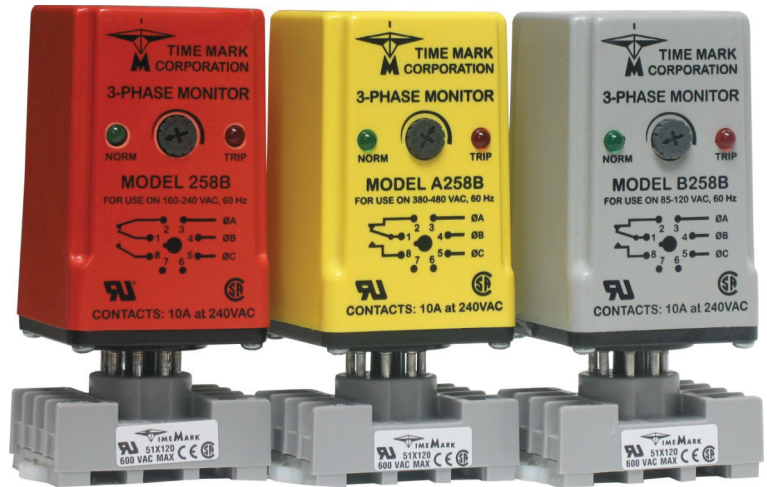

### DESCRIPTION

The **Model 258** continuously monitors 3-phase power lines for abnormal conditions. When properly adjusted, the Model 258 Monitor will detect phase loss on a loaded motor even when regenerated voltage is present.

This device consists of a solid-state voltage and phase-angle sensing circuit, driving an electromechanical relay. When correct voltage and phase rotation are applied, the internal relay will energize. A fault condition will de-energize the relay. When the fault is corrected, the monitor will automatically reset (*a manual reset version is also available*).

The Model 258 3-Phase Monitor does not require a neutral connection and can be used with Wye or Delta systems. Voltage ranges are sufficiently wide to allow for proper adjustment to existing conditions. Both "TRIP" and "NORM" condition indicators are provided to aid in adjustment and system trouble-shooting.



### SPECIFICATIONS

AUTO Reset MANUAL Reset	B258B B258BM	258B 258BM	A258B A258BM	EX258B EX258BM	B258B-400 B258BM-400	258B-400 258BM-400	EX258B-415V
Nominal AC voltage (phase to phase)	120VAC	208/240VAC	480VAC	380VAC	120VAC	208/240VAC	415VAC
Case Color	Gray	Red	Yellow	Yellow	Gray	Red	Yellow
Adjustment range	85-120VAC	160-240VAC	380-480VAC	300-400VAC	85-120VAC	160-240VAC	340-440VAC
Frequency	60Hz	60Hz	60Hz	50Hz	400Hz	400Hz	50Hz
Pwr consumption	1.4W	2.4W	3.7W	3.0W	1.4W	2.4W	3.3W
Transient protection	2500VAC for 10ms						
Repeat accuracy	± 0.1% of set point (fixed conditions)						
Response time	50ms drop out						
Dead band	Approx. 2%						
Output contacts	SPDT 10 amps at 240VAC resistive						
Expected relay life	Mechanical: 10 million operations Electrical: 100,000 operations at rated load						
Operating temp.	-20° to +131° F						
Humidity tolerance	0 - 97% w/o condensation						
Enclosure material	ABS plastic cover						
Mounting	8-pin socket ( **sold separately)						
Weight	5 oz.						
Agency approvals	<b>UL Recognized* and CSA Certified</b> *Conditions of acceptability: (1) the 380V and 480V versions must be used with a UL Recognized 600VAC socket. (2) For use in a Pollution Degree 2 environment (3) To be installed on the load side of branch circuit protection rated 10A.						

\*\* Order 8-pin socket number 51X120

### DIMENSIONS

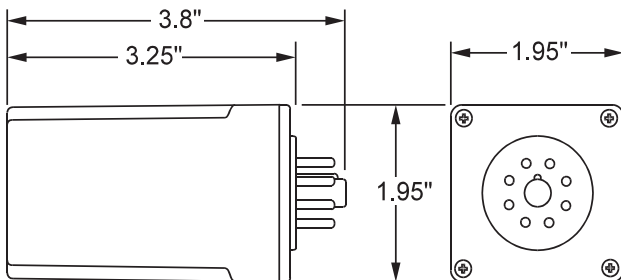

### TYPICAL APPLICATION

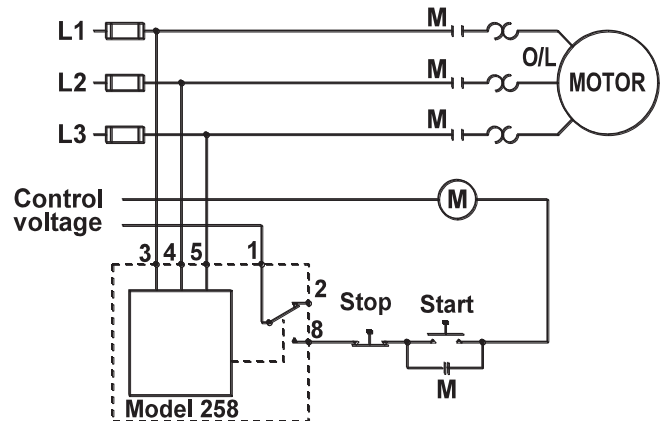

Telephone: Main - (918) 438-1220

Sales - (800) 862-2875

Fax: (918) 437-7584

E-mail: sales@time-mark.com

Internet: http://www.time-mark.com



**TIME MARK**  
CORPORATION

11440 East Pine Street  
Tulsa, Oklahoma 74116

12/2012

© 2012 TIME MARK CORPORATION

TIME MARK is a division of  AEMT, Inc.

# MODEL 258 3-Phase Monitor

READ ALL INSTRUCTIONS BEFORE INSTALLING, OPERATING OR SERVICING THIS DEVICE.  
KEEP THIS DATA SHEET FOR FUTURE REFERENCE.

## GENERAL SAFETY

POTENTIALLY HAZARDOUS VOLTAGES ARE PRESENT AT THE TERMINALS OF THE MODEL 258.  
ALL ELECTRICAL POWER SHOULD BE REMOVED WHEN CONNECTING OR DISCONNECTING WIRING.  
THIS DEVICE SHOULD BE INSTALLED AND SERVICED BY QUALIFIED PERSONNEL.

## Installation Instructions

### WARNING

IN APPLICATIONS WHERE VOLTAGES IN EXCESS OF 300VAC ARE TO BE MONITORED, BE CERTAIN TO USE THE TIME MARK MODEL 51X120 8-PIN SOCKET, OR AN EQUIVALENT UL APPROVED 600VAC RATED SOCKET.

### INSTALLATION

Mount the 8-pin socket in a suitable enclosure. A NEMA-1 rated enclosure, designed for socket-mounted relays is available from Time Mark Corporation.

Connect 3-phase power to terminals 3, 4, and 5 on the socket. Phase rotation should be verified using a Time Mark Model 108A or 108B Phase Sequence Detector.

Connect the load control wiring to the appropriate terminals on the socket:

**For motor control applications;** use terminals 1 and 8.

**For phase loss alarm applications;** use terminals 1 and 2.

Insert the Model 258 into the socket and apply power. If the contact does not transfer (*green light ON*), check that all phases are present, and of the correct voltage. If power is correct, rotate the level adjustment counter-clockwise.

If the contact still does not transfer, remove power and reverse any two of the three phase wires at the socket (*phase rotation is reversed*). Re-apply power. The contact should transfer to provide a signal path between pins 1 and 8.

**NOTE:** When installing the Model 258 monitor in areas of high humidity or contamination, it is recommended that the base area and all exposed metal parts of the socket be coated liberally with a good quality silicone grease, such as Dow Corning DC-4 or DC-4X. Insert the unit into the socket and wipe off excess grease around the base. This will prevent the entrance of moisture and other contaminants into the base and socket areas.

### ADJUSTMENT SETTINGS

The following procedure will allow the Model 258 to be adjusted to achieve a trip point just below the nominal phase-to-phase voltage, where the unit is applied.

Rotate the adjustment control fully clockwise, or until the red (TRIP) indicator illuminates.

Slowly rotate the adjustment control in a counter-clockwise direction, just until the green (NORM) indicator illuminates.

At this point, the Model 258 is the most sensitive to irregular power line conditions. If nuisance tripping occurs, turn the control slightly farther counter-clockwise.

A more accurate setting will require the use of a 3-phase variac to lower the voltage to an exact measurable setting. Time Mark also offers a factory set version of all models and voltage ranges, for only a small additional charge.

### TROUBLESHOOTING

Should the Model 258 Monitor fail to operate properly, check that all three voltages are present, and are of the correct voltage level and phase rotation (a Model 108A or 108B Phase Sequence Detector should be used to verify phase rotation). Check all fuses and verify that all wiring connections are correct. If problems persist, contact your local Time Mark Distributor, or the factory for assistance (*Monday-Friday, 8 a.m. to 5 p.m. CST*).

### MANUAL RESET VERSIONS

IF YOU DO NOT WISH TO USE A NORMALLY CLOSED EXTERNAL RESET SWITCH ON THE MANUAL RESET VERSION, YOU MUST JUMPER PINS 6 AND 7. Refer to the Manual Reset 8-pin diagram.

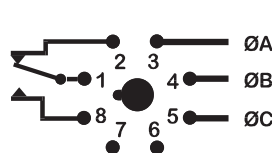

Automatic Reset

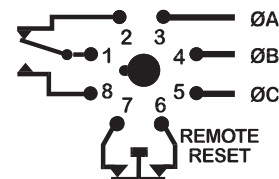

Manual Reset

### WARRANTY

This product is warranted to be free from defects in materials and workmanship, and is covered by our exclusive **5-year Unconditional Warranty**. Should this device fail to operate for any reason, we will repair it for five years from the date of manufacture. For complete warranty details, see the *Terms and Conditions of Sales* page in the front section of the Time Mark catalog or contact Time Mark at 1-800-862-2875.

Telephone: Main - (918) 438-1220

Sales - (800) 862-2875

Fax: (918) 437-7584

E-mail: sales@time-mark.com

Internet: http://www.time-mark.com



**TIME MARK**  
CORPORATION

11440 East Pine Street  
Tulsa, Oklahoma 74116

12/2012

© 2012 TIME MARK CORPORATION

TIME MARK is a division of  AEMT, Inc.